

# MODAL MASTERY

ISSUE 07

FRET BOARD CHARTS

A-Diminished Scale

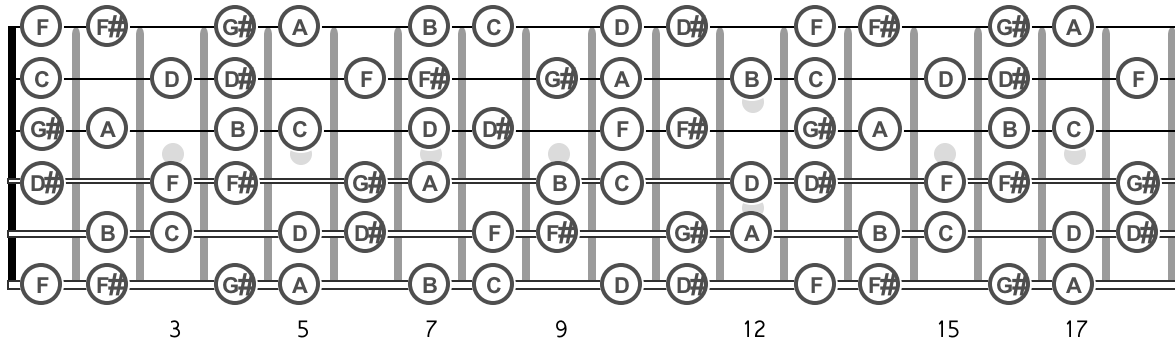

6-String Pattern 1

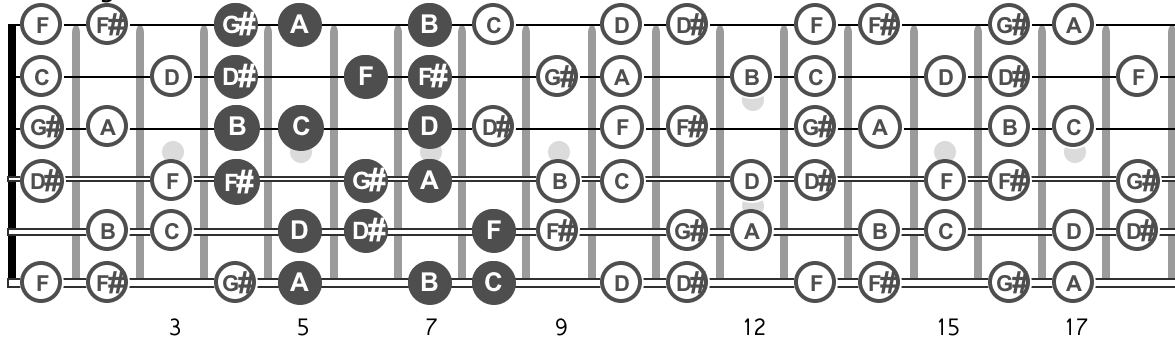

6-String Pattern 2

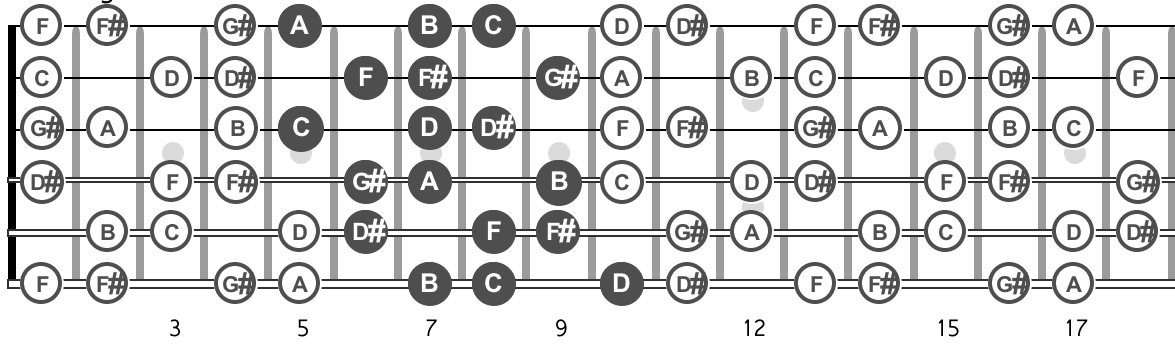

6-String Pattern 1 - repeated a minor third higher

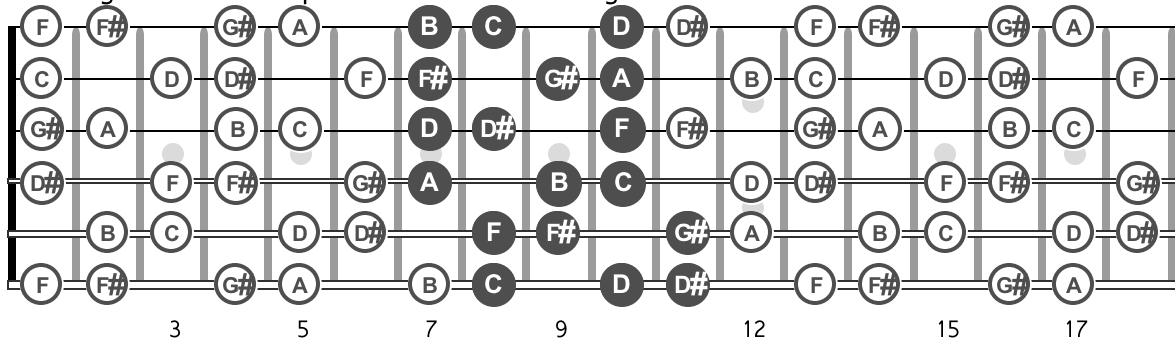

6-String Pattern 2 - repeated a minor third higher

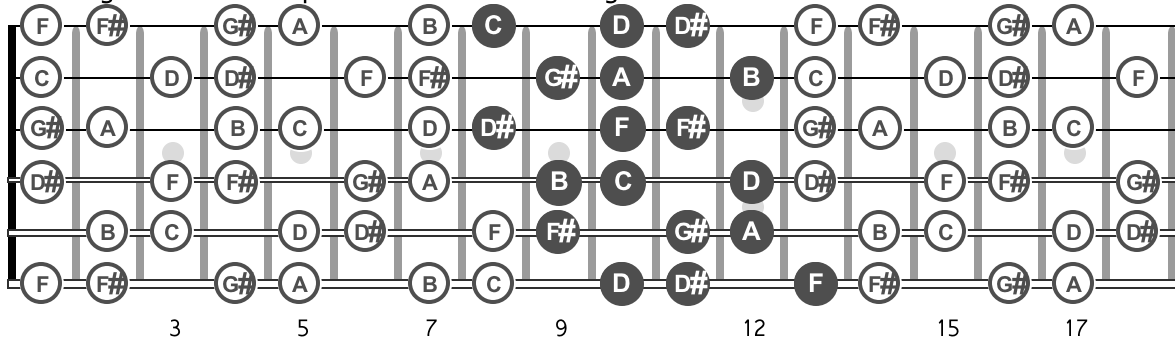

A-Diminished Arpeggio, Scale Shape 1

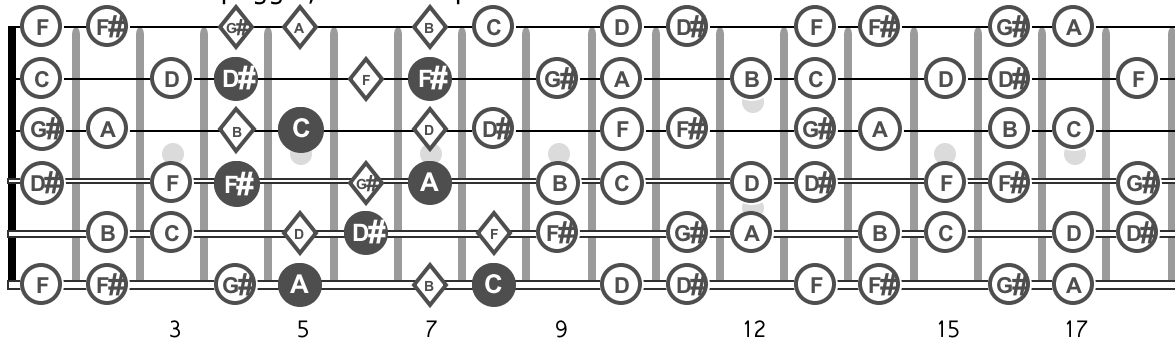

D-Diminished Arpeggio, Scale Shape 1

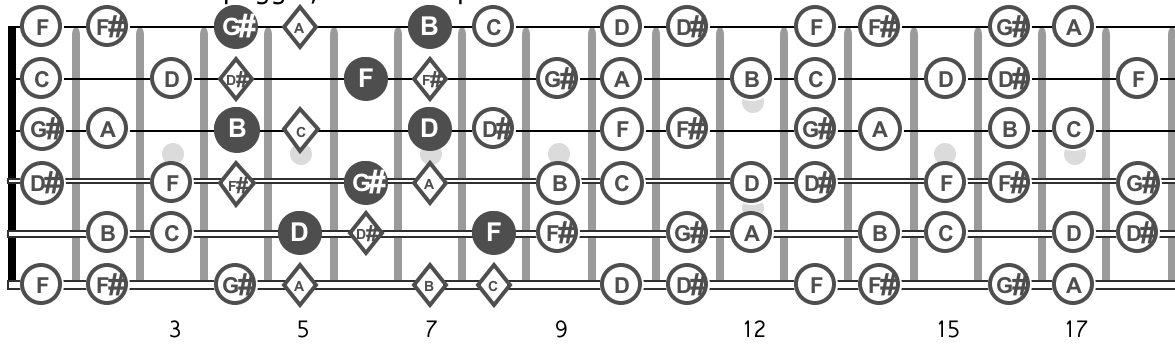

B-Diminished Arpeggio, Scale Shape 2

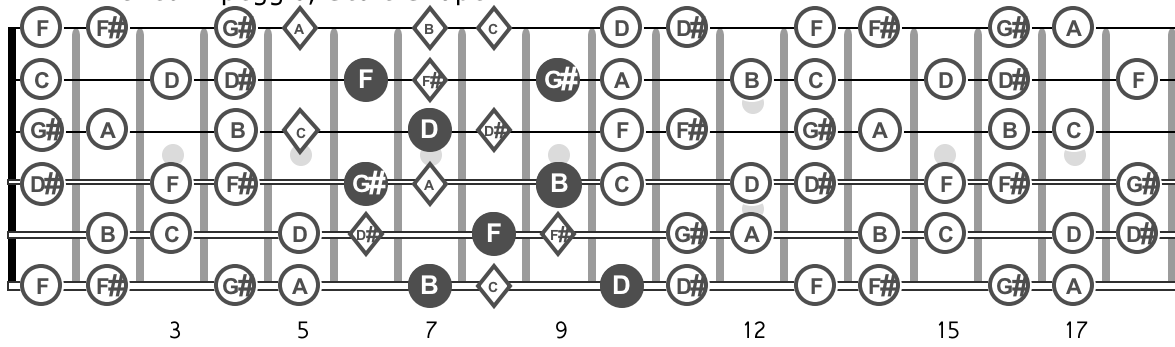

D#-Diminished Arpeggio, Scale Shape 2

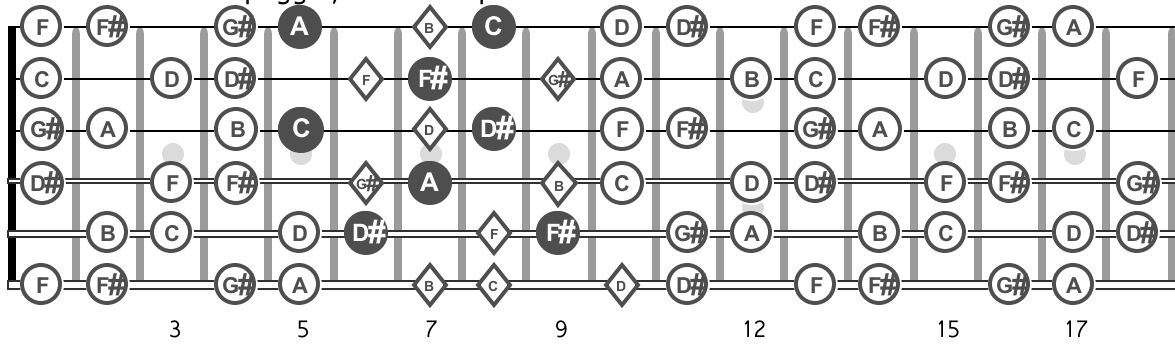

A-Diminished Arpeggio with scale notes - Scale Shape 1

D-Diminished Arpeggio with scale notes - Scale Shape 1

B-Diminished Arpeggio with scale notes - Scale Shape 2

D#-Diminished Arpeggio with scale notes - Scale Shape 2

A-Tritone Power Chord

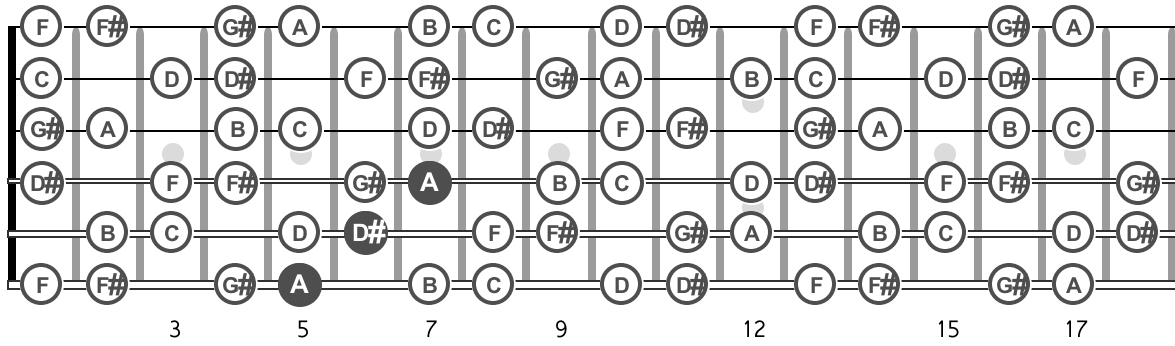

B-Tritone Power Chord

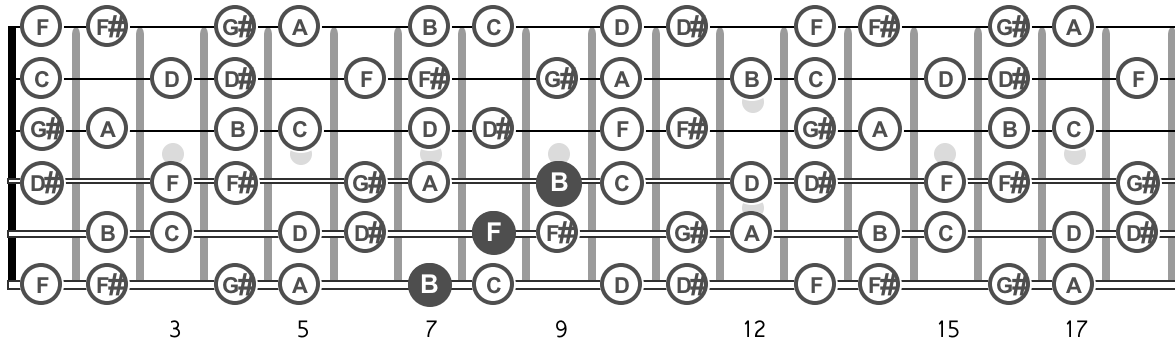

B-Power Chord (Root & fifth, no third)

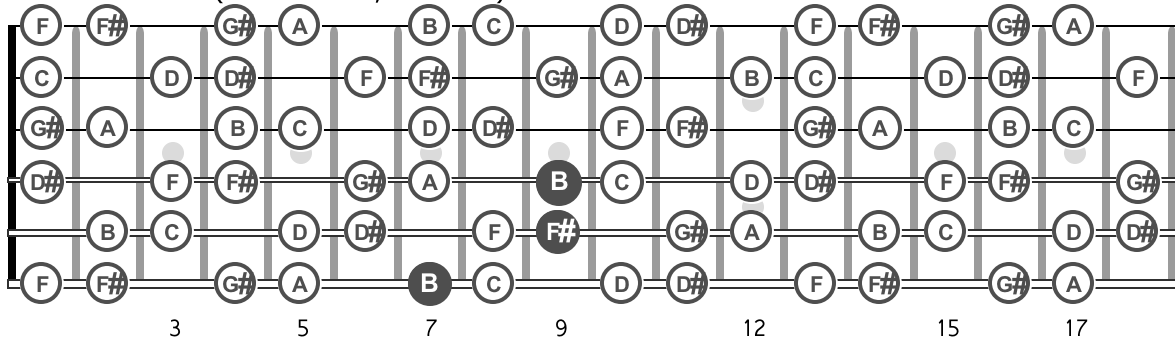

C-Tritone Power Chord

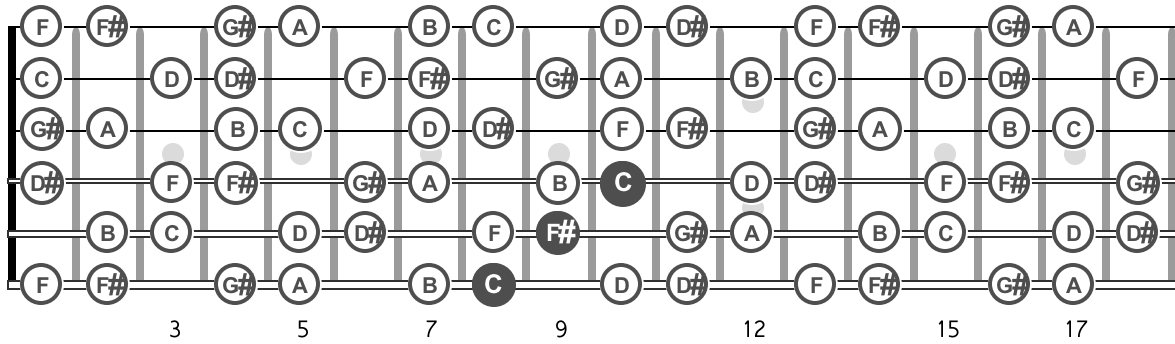

D-Power Chord (Root & fifth, no third)

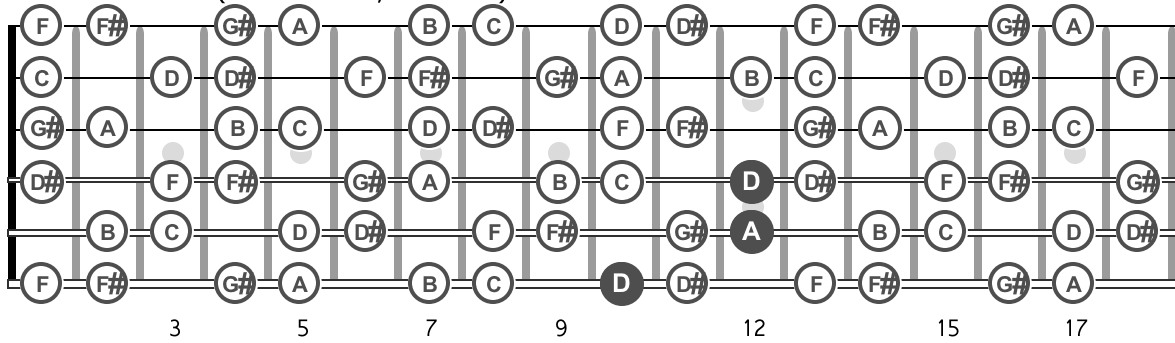

A-Diminished Chord (E-String Root)

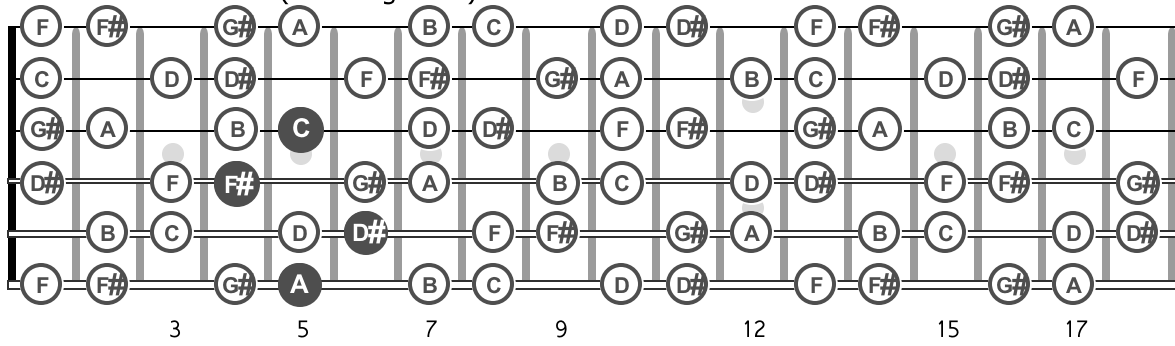

B-Diminished Chord (E-String Root)

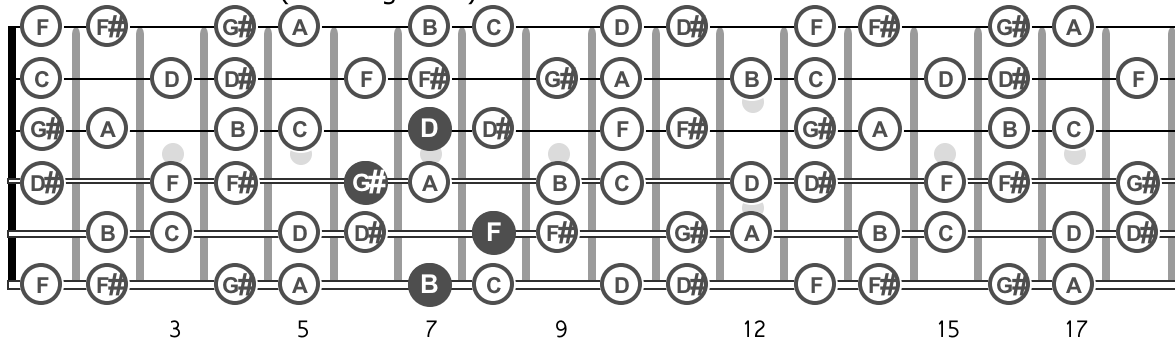

A-Diminished Chord (All six strings)

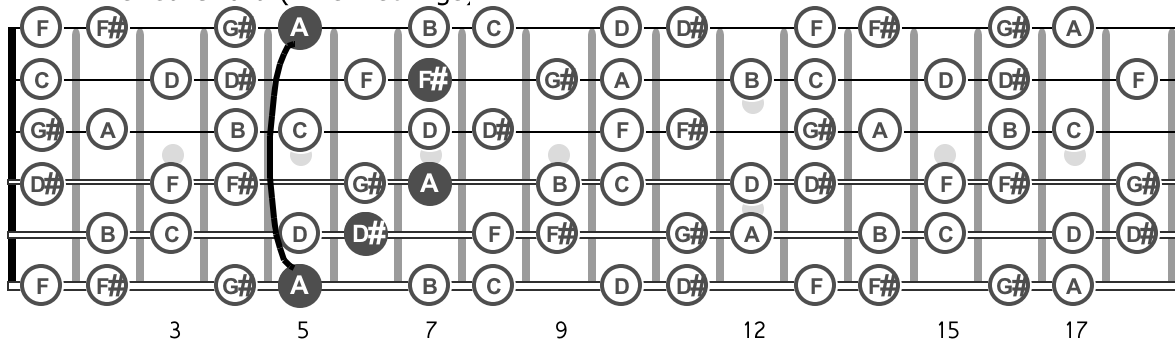

D-Diminished Chord (A-String Root)

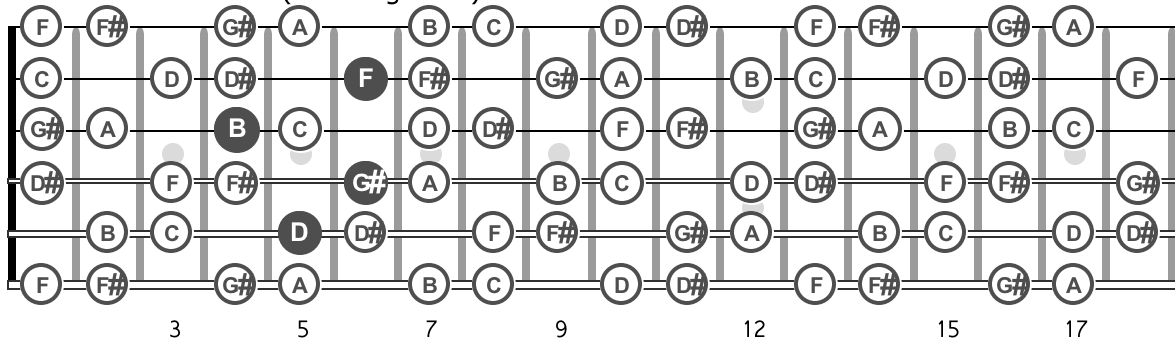

D-Diminished Chord (5-Strings)

